



Kardeşler Makina A.Ş.

Adres : Topçular Kışla Cad. Apek Üretmen İş Merk.
C Blok No:61/71-95

Bayrampaşa / İSTANBUL

Tel : +90(212) 544 3733 - 612 6216 - 565 7926

Fax : +90(212) 501 7023 - 493 0866

e-posta : info@kardeslermakina.com.tr

Url : <http://www.kardeslermakina.com.tr>

BD – 665 / 60

ÇİZİM

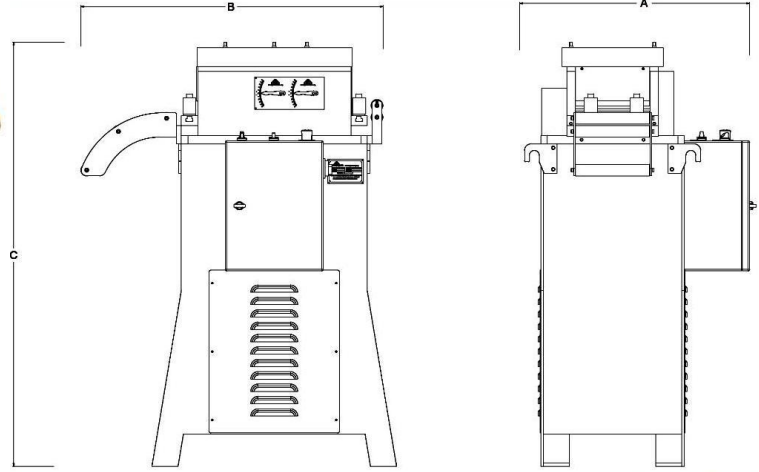

KODU	665-60/5M	665-60/7M
A	1145	1145
B	950	1050
C	1300	1300

ÜRÜN ÖZELLİKLERİ

Maksimum Rulo Eni	665mm
Min./Max. Bant Kalınlığı	0,8 – 3,5mm
Max. Malzeme Kesiti	665 x 3mm
Doğrultucu Merdane Adetleri	5 / 7 / 9 / 11
Merdane Çapı	60mm
Max. Boşaltma Hızı	25m/dk
Motor	3 kW
Güç Kaynağı	380V
Tahrip Tipi	AC Motor Rediktörlü Hız Kontrollü